



Engineering Specifications for **SeaShield Series 2000HD** Steel and Concrete Pile Protection

1.0 Scope

- 1.1 This specification may be used for the materials and application of Premier SeaShield Series 2000HD for protection of steel and concrete piles.
- 1.2 The Engineer shall select appropriate sections of the specification to insure that the specification is comprehensive for specified work.

2.0 General Requirements

- 2.1 Contractor shall comply with all written recommendations of the manufacturer regarding application of the specified system.
- 2.2 The manufacturer of specified materials shall be Premier Coatings Ltd., 9710 Telge, Houston, TX 77095, Telephone: 281-821-3355 or 90 Ironside Crescent Unit 12, Toronto, Ontario, Canada M1X1M3 Telephone: 416-291-3435.
E-mail: info@premiercoatings.com

3.0 Materials

- 3.1 Prempaste S105 Primer
 - 3.1.1 The Prempaste S105 Paste shall be comprised of saturated petroleum hydrocarbons (petrolatum), inert fillers and passivating agents.
 - 3.1.2 The paste is used to displace moisture, passivate surface oxides and fill surface imperfections.
 - 3.1.3 The Prempaste S105 Paste shall meet the physical specification values listed on the product data sheet. If the surface to be protected is pitted by 2mm or more in depth then a layer of Prempaste S105 Paste should be applied over the pitted area.
- 3.2 Premier Molding Compound
 - 3.2.1 The Premier Molding Compound shall be comprised of saturated petroleum hydrocarbons (petrolatum), inert fillers, reinforcing fibers and thermal extenders. Variations may contain beads of cellular polymer and flow control additives.
 - 3.2.2 Premier Molding Compound shall be cold applied self supporting Mastic for molding around irregular shaped fittings to provide a suitable profile for applying the SeaShield Tapes.
 - 3.2.3 The physical specification values shall meet the values given on the product data sheet for the type of premier Molding Compound required.

3.3 Premier Tapes

3.3.1 The Premier Coatings Marine Piling Tape is used for cylindrical, square & octagonal piles. It shall be comprised of a non-woven synthetic fabric carrier fully impregnated and coated with a neutral petrolatum based compound with inert siliceous fillers and inhibitors with an HDPE backing.

The Premier Coatings is used for H-piles. It shall be comprised of a non-woven synthetic fabric carrier fully impregnated and coated with a neutral petrolatum based compound with inert siliceous fillers and inhibitors.

3.3.2 The Premier Coatings Marine Piling Tape & Premier Coatings Tape shall have a character stable in composition and plasticity over a wide temperature range. The tape shall be non-hardening and non-cracking. The tape shall accommodate vibration and extreme movement of substrate. Superficial oxidation renders surface less tacky. Highly resistant to mineral acids and alkalies.

3.3.3 The Premier Coatings Marine Piling Tape & Premier Coatings shall meet the physical specifications values listed on the product data sheet.

3.4 SeaShield Outcover

3.4.1 The SeaShield Outcover shall be comprised of High Density Polyethylene (HDPE). It shall be new, seamless virgin material. Use of reprocessed resin is prohibited. The sheet shall be uniform throughout, free from dirt, oil and other foreign matter and free from cracks, creases, wrinkles, bubbles, pin-holes and any other defects that may affect its service.

3.4.2 The Outcover shall be 80 mils (2032 microns) thick to prevent damage to underlying tape. The outcover shall be custom fabricated to the diameter of the pile. They shall be fabricated in 1' (0.3 m) increments in lengths from 2' (0.6 m) to 10' (3 m) as needed. Multiple outcovers with 2" (50 mm) lip extensions for overlapping, shall be utilized as needed. If necessary, outcovers can be custom cut to desired length in the field. SeaShield Fasteners will be spaced evenly depending on size and length of outcover.

3.4.3 Physical properties of the outcover shall meet or exceed the minimum requirements listed on the product data sheet for the SeaShield Outcover.

3.5 SeaShield Fasteners

3.5.1 The SeaShield Fasteners shall be comprised of M10 x 150 mm Bolt, 316 Stainless Steel.

3.5.2 M10 Nyloc Nut, 316 Stainless Steel.

3.5.3 M10 Penny Washer O.D. 35 mm x 1.5 mm thick, 316 Marine Grade Stainless Steel for every nut and bolt there are two washers.

3.5.4 Torque Specification up to 40 to 80 in. lb. (4.5 to 9.0 N/m) (Torque wrench capable of reading a minimum of 25 in. lb. / 2.8 N/m is required.)

3.5.5 A thin coat of anti-sieze compound shall be applied to bolt prior to tightening to prevent possible galling.

4.0 Surface Preparation Requirements

4.1 Remove weld spatter, sharp points and edges.

4.2 Remove marine growth, loose rust, loose paint and foreign matter by hand and /or power tools cleaning in accordance with SSPC-SP-2, or SP-3, "Hand Tool Cleaning" or "Power Tool Cleaning" respectively.

4.3 A hydraulic whirl away or high pressure water blasting may be used to prepare the surface.

5.0 Application of Prempaste S105 Paste

5.1 If surface has corrosion pits greater than 2 mm, apply a thin uniform layer of Prempaste S105 over corroded area and fill all pits.

5.2 When applying the Prempaste S105 Paste underwater use a gloved hand to displace the water and slowly rub S105 Paste onto surface and into pits. (Note: When applying underwater the primer will be less visible on the pile.)

6.0 Application of Premier Mastics

6.1 To protect complex surfaces and configurations such as brackets, flanges, valves etc., apply Premier Molding Compound or Prembond Mastic by filling and packing to achieve a uniform contour to which tape can be applied without bridging or voids.

6.2 Use Premier Molding Compound to fill in cavities at the pile/ pile cap interfaces.

7.0 Cylindrical Pile - Application of Premier Coatings Marine Piling Tape

7.1 The Premier Coatings Marine Piling Tape shall be spirally wrapped onto pile using a 55% overlap, which will provide a double thickness of tape throughout.

7.2 Hold end of the tape firmly against the starting point and firmly press on the surface. Unroll the tape, keeping the roll close to the surface. Do not get a long lead of tape as it will tend to fold and gap on the surface being wrapped.

7.3 Apply sufficient tension to provide continuous adhesion, but do not stretch the tape. As application proceeds, press out all folds and air pockets that may occur.

7.4 Maintain a minimum 6" (150 mm) overlap when overlapping one roll with the end of a new roll.

7.5 At the completion of each roll, smooth the overlaps by hand in the direction of the spiral to insure sealing of the overlap.

8.0 H-Pile - Application of SeaShield Foam Blocks and Premier Coatings Tape

8.1 Wrap foam blocks with Premier Coatings Tape with minimum 1" (25 mm) overlap.

8.2 Insert the wrapped foam blocks into the openings of the H-Piles on each side, ensuring a tight fit.

8.3 The Premier Coatings Tape shall be spirally wrapped around the H-Pile using a 55% overlap, which will provide a double thickness of tape throughout.

8.4 Hold end of the tape firmly against the starting point and firmly press on the surface. Unroll the tape, keeping the roll close to the surface. Do not get a long lead of tape, as it will tend to fold and gap on the surface being wrapped.

8.5 Apply sufficient tension to provide continuous adhesion, but do not stretch the tape. As application proceeds, press out all folds and air pockets that may occur.

8.6 Maintain a minimum 6" (150 mm) overlap when overlapping one roll with the end of a new roll.

8.7 At the completion of each roll, smooth the overlaps by hand in the direction of the spiral to insure sealing of the overlap.

9.0 Application of SeaShield Outercover

9.1 Locate the outercover between the elevations indicated in the specifications and drawings.

9.2 Wrap the outercover tight around the pile and align the holes within the fastener bars.

9.3 Using the specified nuts, bolts and washers as described in section 3.5, tighten and secure the outercover with a pneumatic wrench to a torque specification of 40 to 80 in.lb. (4.5 to 9.0 N/m).

10.0 Installation of Stopper Bands for H-Piles

10.1 Locate the elevations at the top of the highest jacket and at the bottom of the lowest jacket.

10.2 Remove the release paper from the Butyl Mastic Tape.

10.3 Install two halves of the stopper band at the located elevations. Insert bolt & nut and tighten until stopper band is secured.



HOUSTON:
9710 Telge Drive,
Houston, Texas,
U.S.A. 77095
Tel: 1-281-821-3355
Fax: 1-281-821-0304

TORONTO:
90 Ironside Crescent,
Unit 12, Toronto,
Ontario, Canada M1X1M3
Tel: 1-416-291-3435
Fax: 1-416-291-0898

e-mail: info@premiercoatings.com

www.premiercoatings.com

A Member of Winn & Coales International

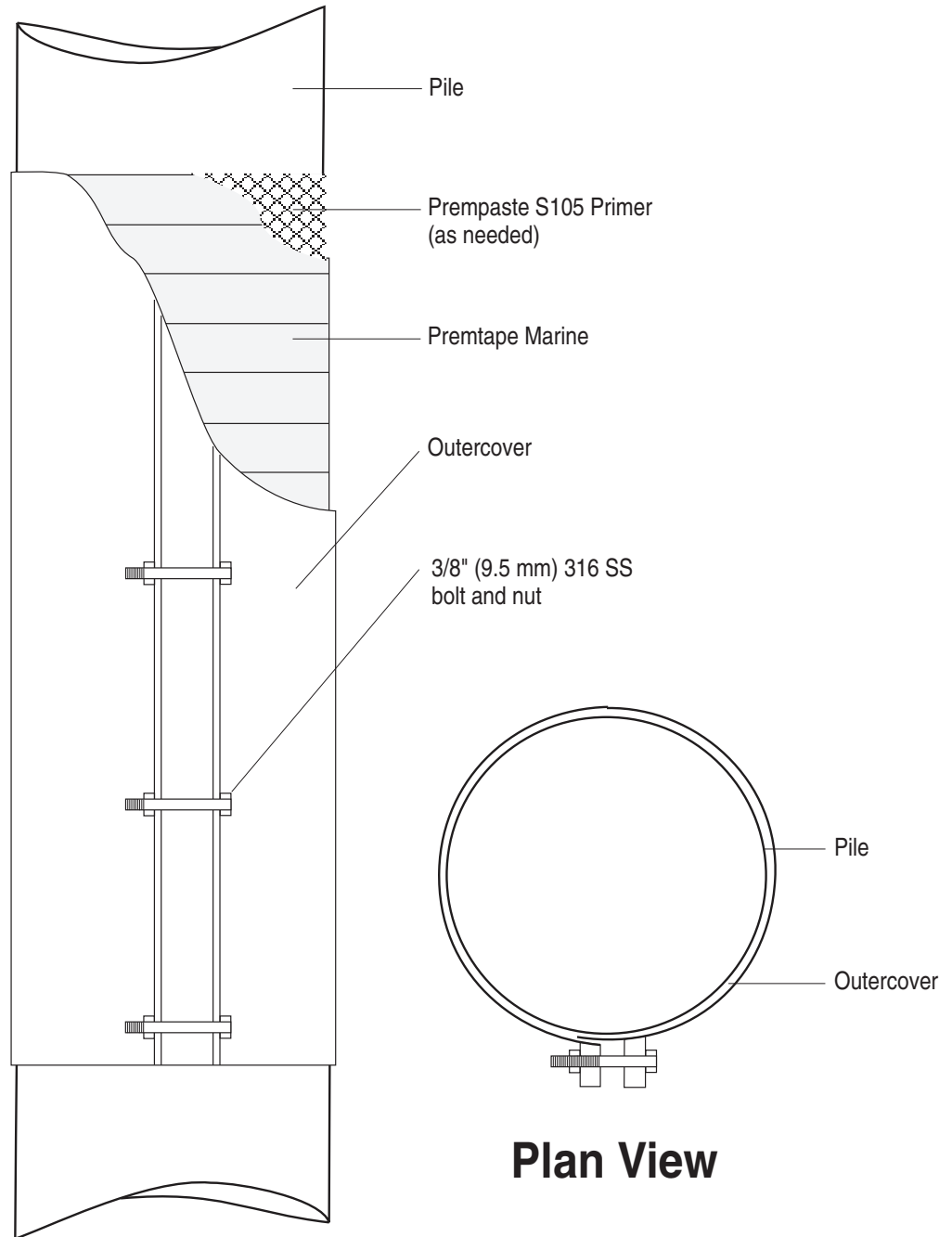

Elevation View

Plan View

Sheet 1
(Not to Scale)

**SeaShield Series 2000HD
Splashzone Protection System**



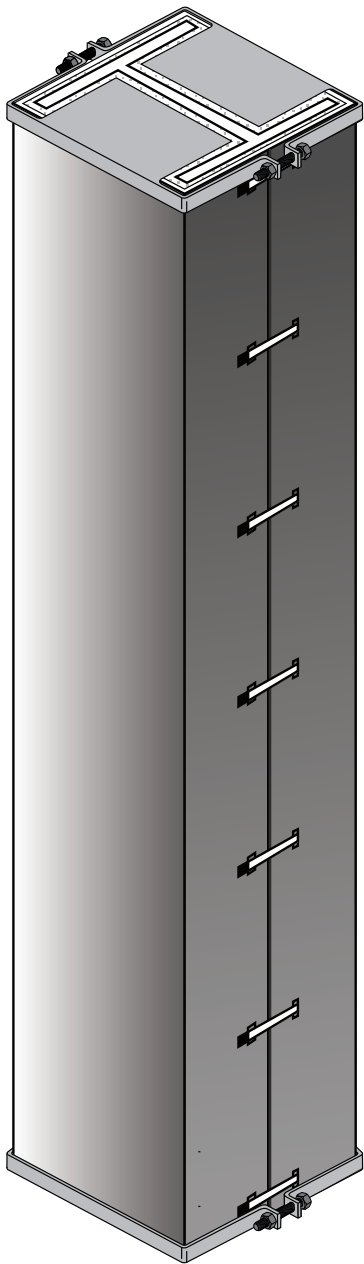

Elevation View

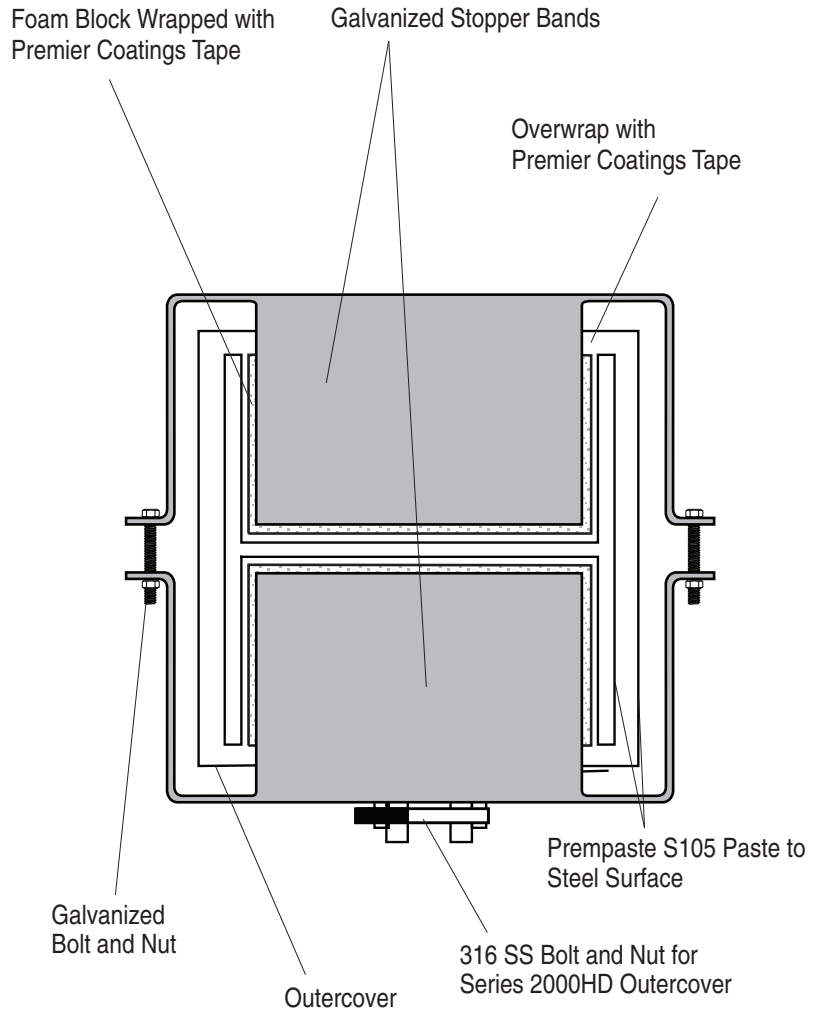

Plan View

Sheet 2
(Not to Scale)

SeaShield Series 2000HD H-Pile Splashzone Protection System

