



Flange & Valve Wrapping - Premier Petrolatum Tape System Specification Guide

1.0 Scope

- 1.1 The following specification is intended to demonstrate the best way to wrap flanges & valves using The Premier Petrolatum Tape System. This system comprises of Prembond Mastic used to fill the voids and smooth the contours prior to over wrapping with Premtape Tropical. This system can then be protected against mechanical damage by the use of a suitable Premier outerwrap. Because the shapes and sizes of valves vary so much, the illustrations are not drawn to scale and are intended to be used for reference only.
- 1.2 The Engineer shall select appropriate sections of the specification to ensure that the specification is comprehensive for specified work.

2.0 General Requirements

- 2.1 Contractor shall comply with all written recommendations of the manufacturer regarding applications of the specified system.
- 2.2 To obtain the specified materials contact Premier Coatings:
USA - 9710 Telge / Houston, TX / 77095 / Tel: 281-821-3355 / Fax: 281-821-0304
CANADA - 90 Ironside Crescent Unit 12 / Toronto, Ontario / M1X1M3 / Tel: 416-291-3435 / Fax: 416-291-0898 **E-MAIL** - info@premcoatings.com

3.0 Materials

3.1 Prempaste / Prempaste S105

- 3.1.1 The paste shall be comprised of saturated petroleum hydrocarbons (petrolatum), inert fillers and passivating agents.
- 3.1.2 The paste shall be an integral component of the tape system for the preparation of the steel surface prior to wrapping. The paste shall displace moisture, passivate surface oxides, fill surface imperfections and ensure intimate contact between mastic and / or tape.
- 3.1.3 The physical specification values shall meet the values given on the data sheet for Prempaste or Prempaste S105.

3.2 Prembond Mastic

- 3.2.1 The mastic shall be comprised of saturated petrolatum hydrocarbons (petrolatum) inert fillers, reinforcing fibers, thermal extenders, beads of cellular polymer and flow control additives.
- 3.2.2 The mastic shall be cold applied self-supporting mastic for molding around irregular shaped fittings to provide a suitable profile for applying Premtape Tropical.
- 3.2.3 The physical specification values shall meet the values given on the data sheet for Prembond Mastic.

3.3 Premier Petrolatum Tapes (Premtape Tropical, Premtape LT & Prembond Colorflex Tape)

- 3.3.1 The tape shall have a character stable in composition and plasticity over wide temperature range. The tape shall be non-hardening and non-cracking. The tapes shall accommodate vibration and extreme movement of substrate. The tape shall be highly resistant to mineral acids and alkalis. Superficial oxidation renders less tacky.
- 3.3.2 The physical specification values shall meet the values given on the data sheets for Premier Petrolatum Tapes.

4.0 General Surface Preparation Requirements

- 4.1 Remove dirt, grease and oil including excessive moisture and frost in accordance with the requirements of SSPC-SP-1, "Solvent Cleaning".
- 4.3 Remove loose rust, paint and foreign matter by hand and / or power tool cleaning in accordance with SSPC-SP-2, or SP-3, "Hand Tool Cleaning" or "Power Tool Cleaning" respectively.

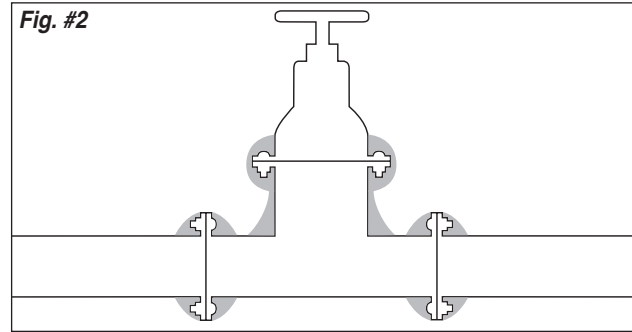
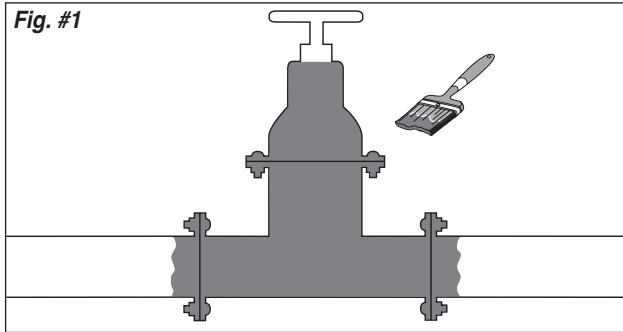

5.0 Application of Prepaste or Prepaste S105

- 5.1 Apply Prepaste or Prepaste S105 by hand, brush, glove, rag or roller.
- 5.2 Apply a thin uniform film over the entire surface to be wrapped.
- 5.3 Apply a liberal coating to threads, cavities, shoulders, pits, etc (See fig #1).

6.0 Application of Prebond Mastic

- 6.1 Fill all voids with Prebond Mastic and build up the profile around the valve flanges and shoulders so that there are no sharp angles. This is to facilitate easy tape wrapping, minimize wrinkles / folds and reduce air entrapment (See fig #2).

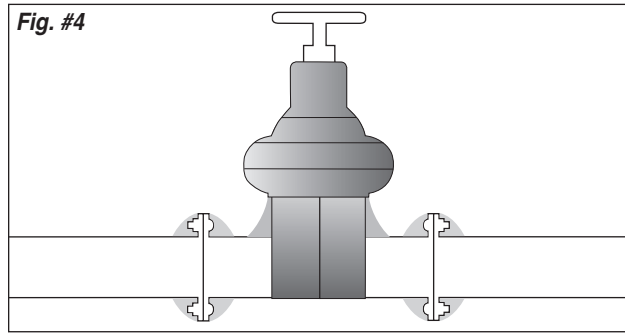
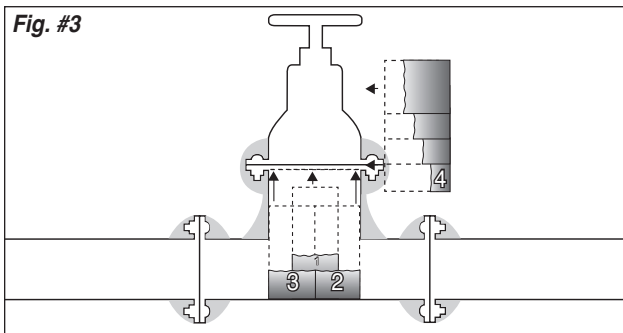

7.0 Application of Premier Petrolatum Tape

- 7.1 Measure and cut the first pieces (1 to 3) of tape and then apply them to the valve body, following the numerical sequence shown in the diagram. These vertical tape pieces go right around the bottom of the valve and up the opposite side forming a "U" shape. When applied in this manner the tape forms a double layer over the center of the valve body. The number of tape pieces used in this stage should be adjusted in accordance with the width of the tape used and the size of the valve. The horizontal piece (4) of tape is spirally wrapped around the valve top. Starting from below the valve shoulder and covering the ends of the vertical tape pieces in a weatherboard manner and then working up towards the top of the valve. Make sure the tape does not interfere with the movement of the valve wheel or mechanism. Smooth down the tape and its edges to remove air and form a seal (See fig #3).
- 7.2 The first pieces of tape in position (See fig #4).

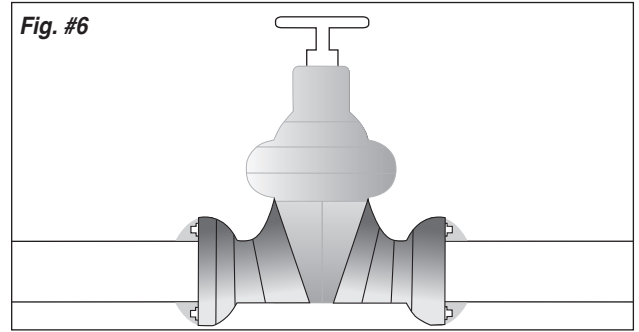
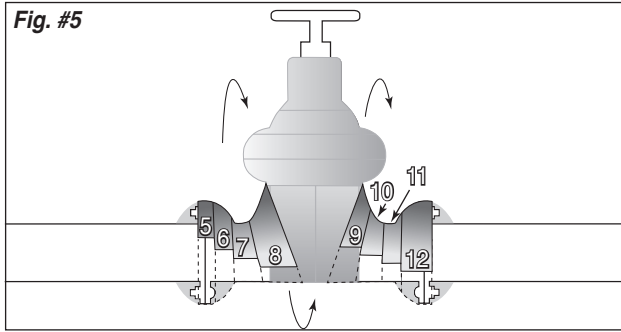

7.3 Next, the tape is applied directly from the roll in one continuous piece and the numbers on the diagram refer to the number of circumferential wraps. The tape should be applied using a 55% overlap to give a double layer. Starting at the top of the center of the valve flange on one side and moving towards the valve body, wrap the first few turns vertically whilst gradually moving to a diagonal direction as the tape approaches and overlaps onto the previously applied tape pieces. Take the tape diagonally across the center of the valve and continue on the other side working towards the opposite flange in a repeat of the first side. Smooth down the tape and its edges to remove air and form a seal. The number of circumferential wraps used in this stage should be adjusted in accordance with the width of the tape used and the size of the valve (See fig #5).

7.4 The completed wrap (See fig #6).

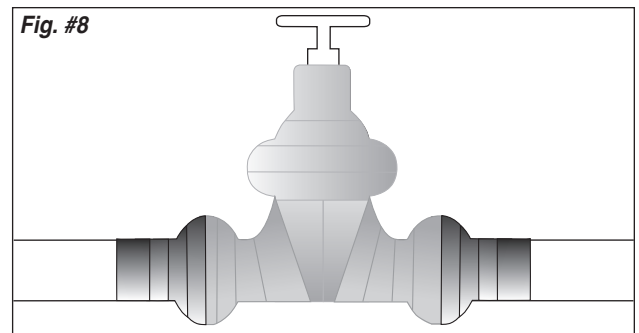
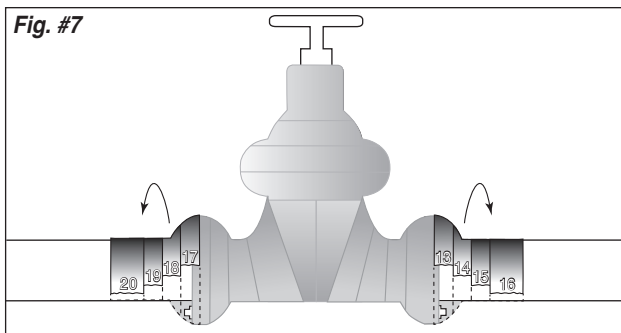

7.5 The final tape wrap starts on the top of the center of the flange and overlaps onto the previous tape. Working away from the flange onto the connected pipework in a vertical motion, the tape is applied using a 55% overlap to give a double thickness. This application is repeated on the other side of the valve to complete the wrapping. Smooth down the tape and its edges to remove air and form a seal (See fig #7).

7.6 The completed tape wrap (See fig #8).

8.0 Tape Outerwrap (Optional)

8.1 If a Premier tape outerwrap is specified for mechanical protection purposes, it should be applied in a manner similar to section 7.0 or best method. Refer to specific product data sheet (Premier Poly-Wrap, Viscotag PVC Outerwrap or Premcote Glass Outerwrap).



HOUSTON:
9710 Telge Road,
Houston, Texas,
U.S.A. 77095
Tel: 281-821-3355
Fax: 281-821-0304

TORONTO:
90 Ironside Crescent,
Unit 12, Toronto,
Ontario, Canada M1X1M3
Tel: 416-291-3435
Fax: 416-291-0898

www.premcoatings.com

info@premcoatings.com

**A Member of Winn
& Coales International**